

TCK系列数控车床

电气原理图

系统型号：HNC808DT

山东鸿运来工业科技有限公司

目 次

1	共用电路.....	1-1
2	CNC 电路.....	2-1
3	主轴电路.....	3-1
4	伺服轴电路.....	4-1
5	刀架电路.....	5-1
6	卡盘电路.....	6-1
7	台尾电路.....	7-1
7.1	台尾套筒.....	7-1
7.2	台尾体.....	7-3
8	自动门电路.....	8-1
9	备 注.....	9-1

1 共用电路

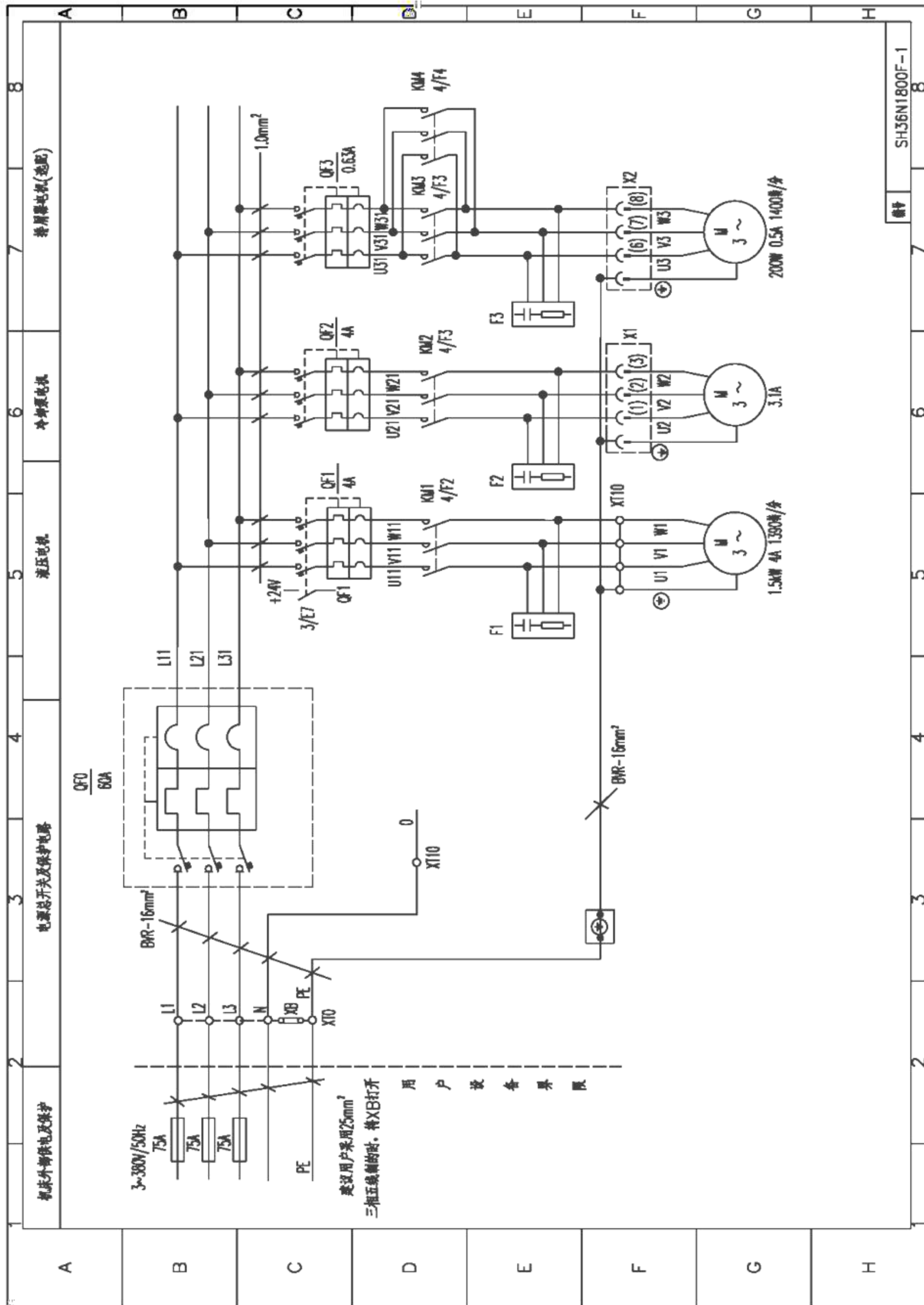

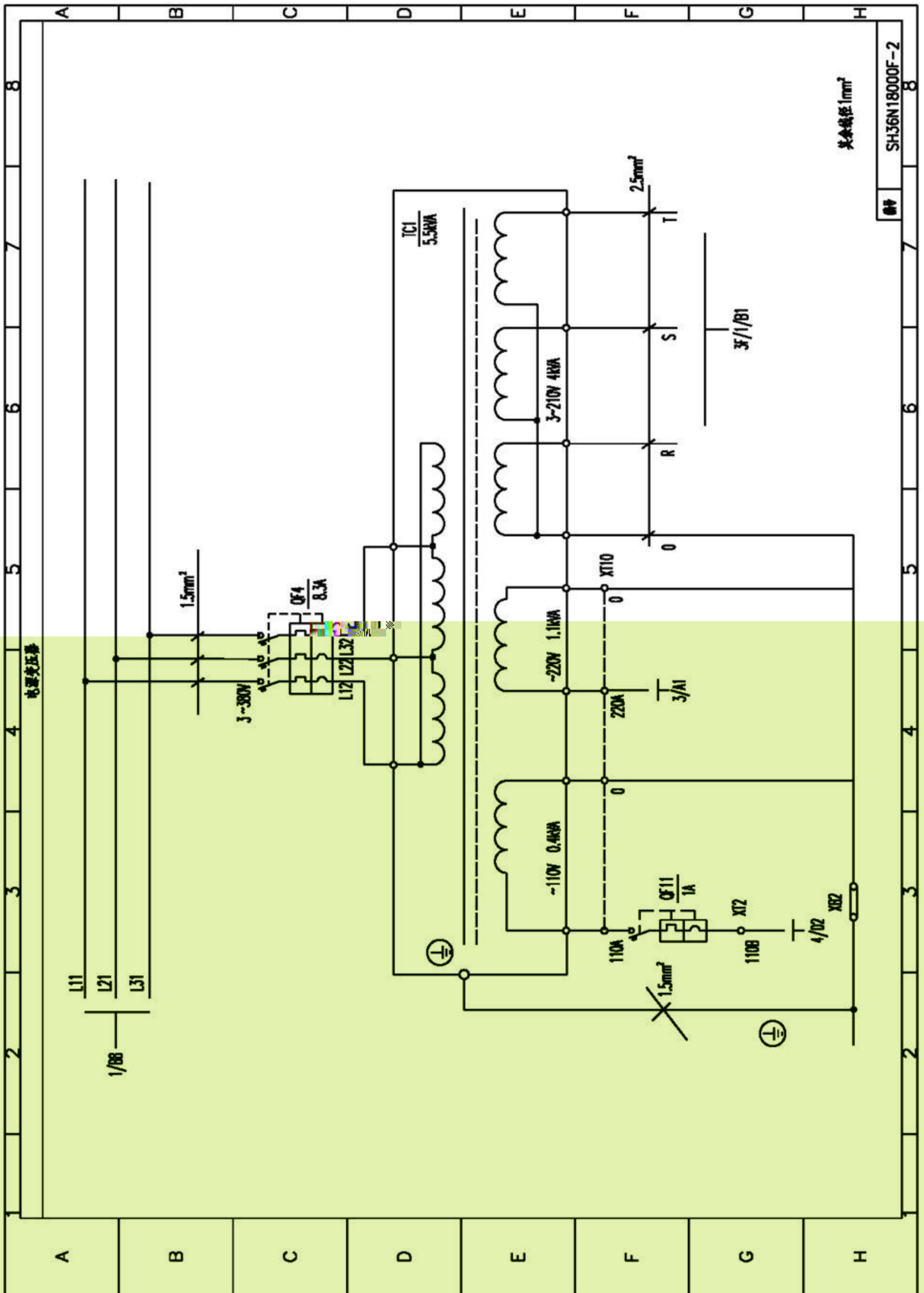

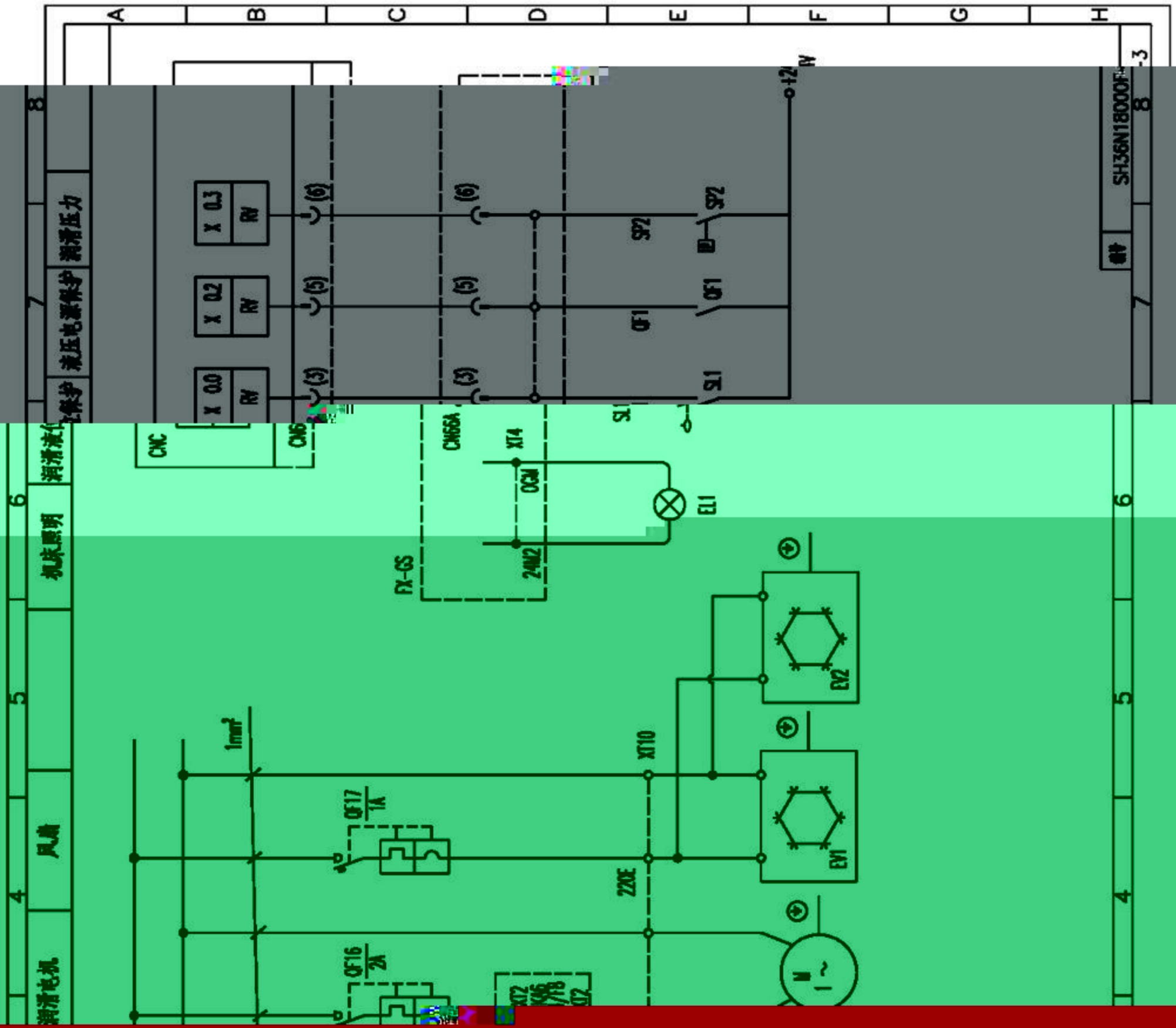

4	4	5	6	8
润滑电机	风扇	机床照明	润滑液位	油压保护
				油压电源保护
				油压压力

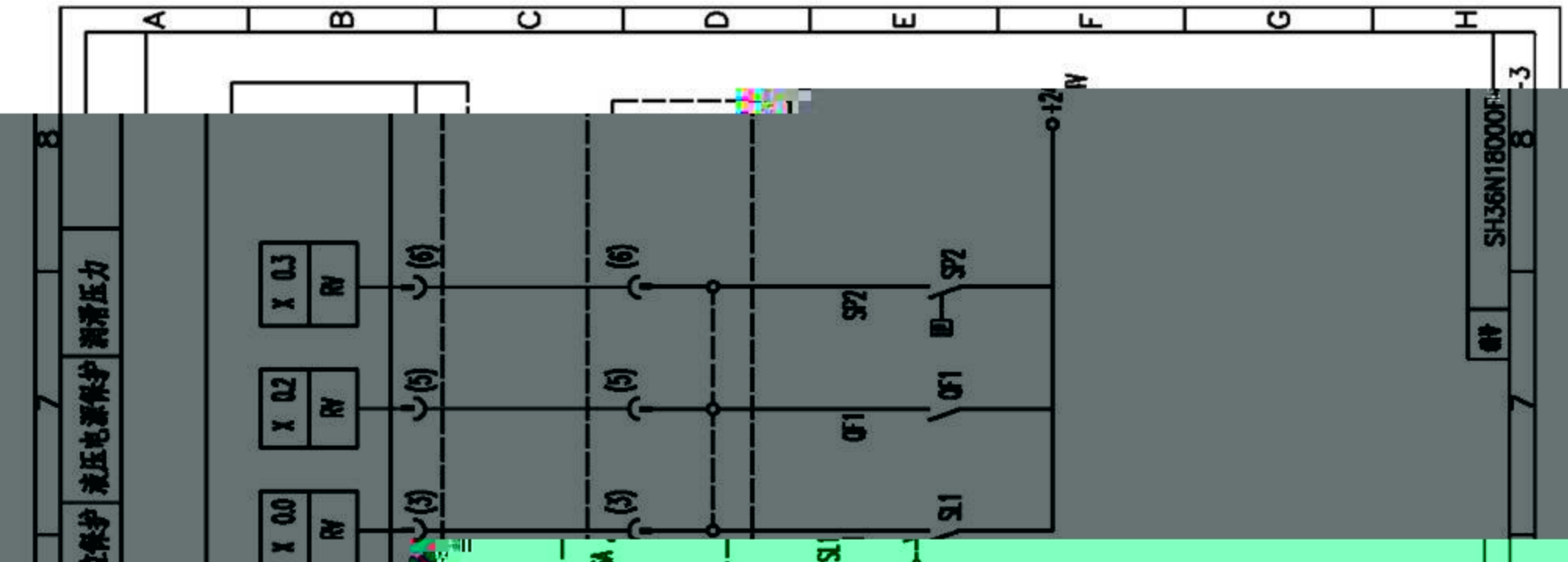

SH36N18000F

8-3

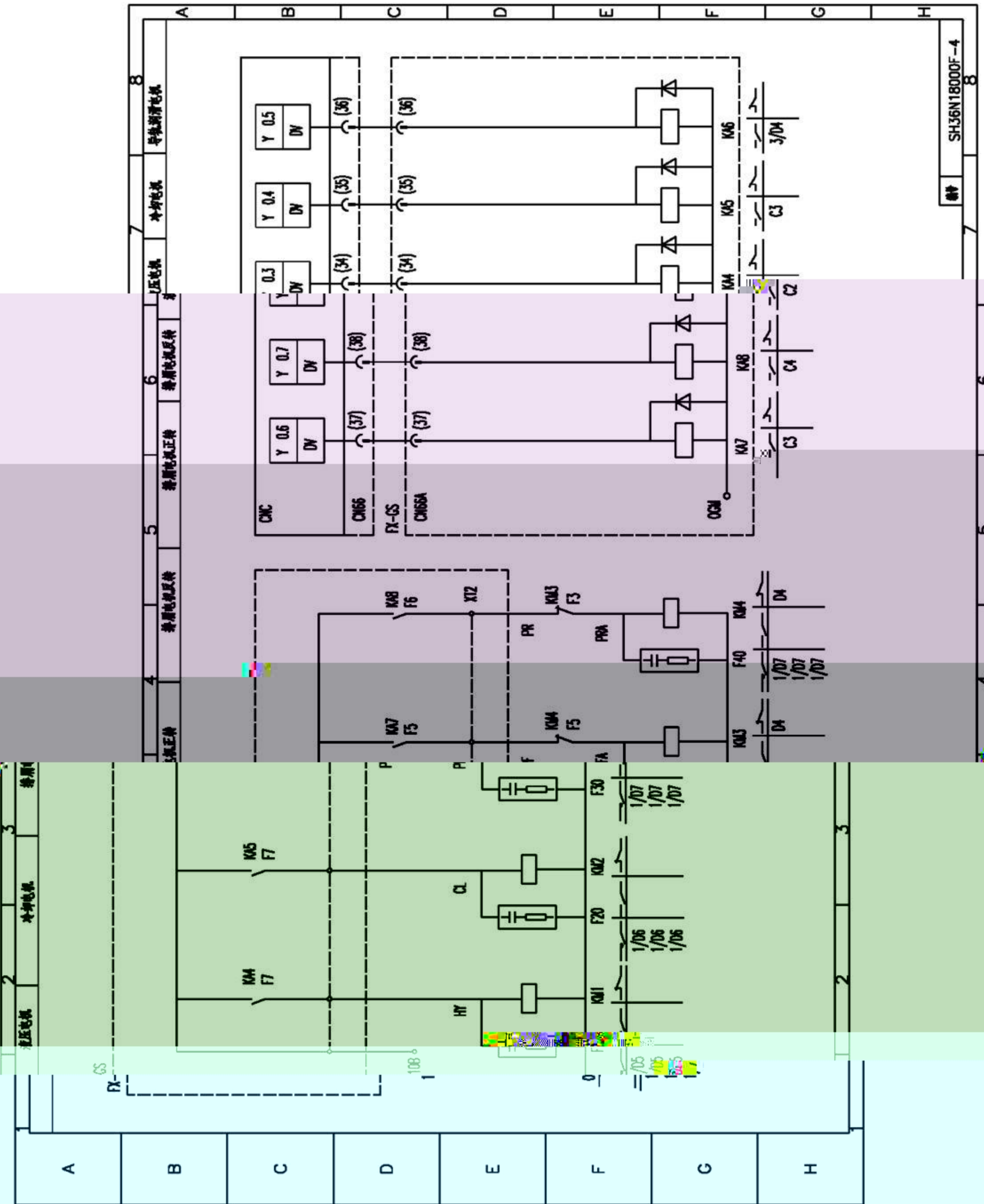

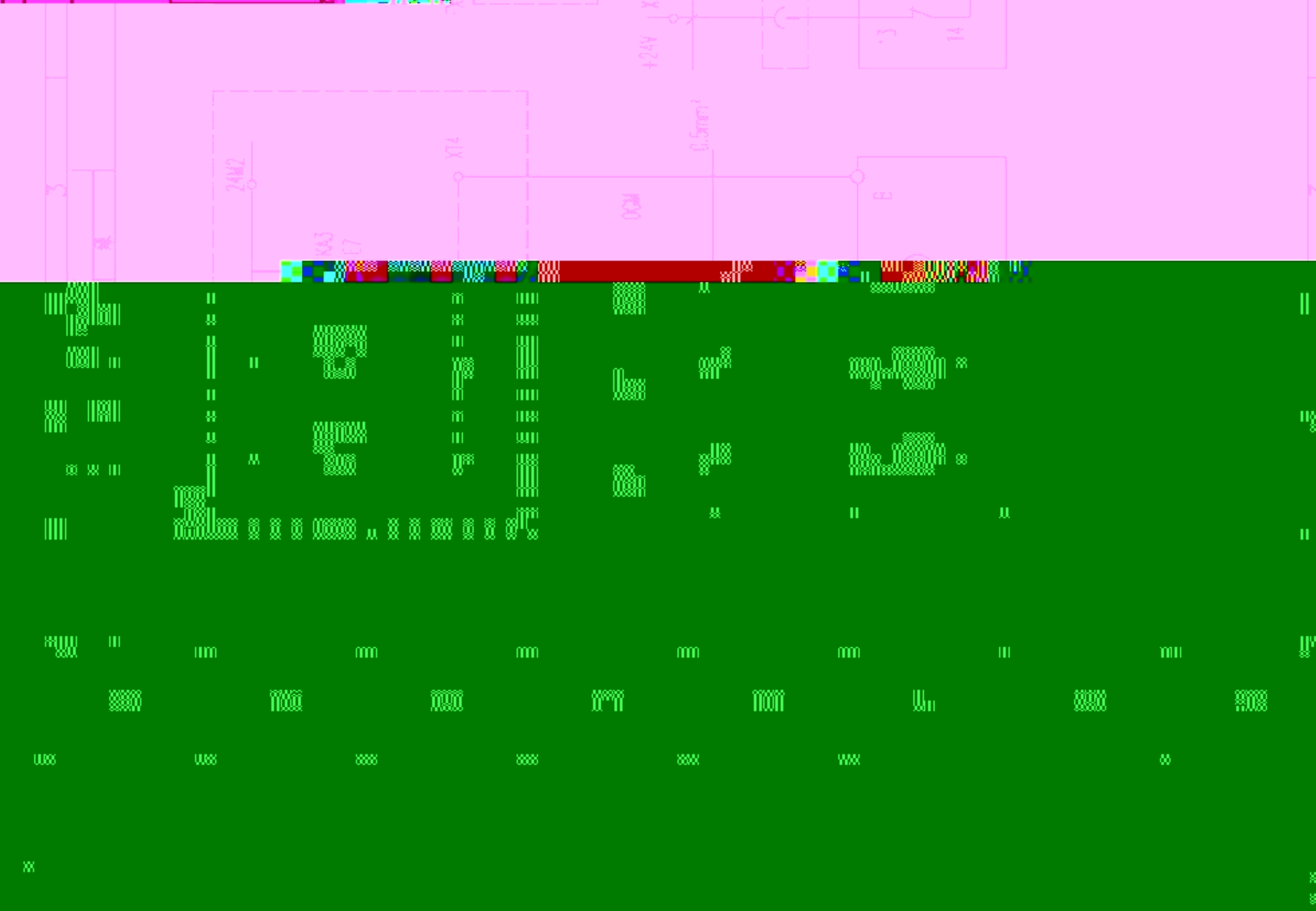
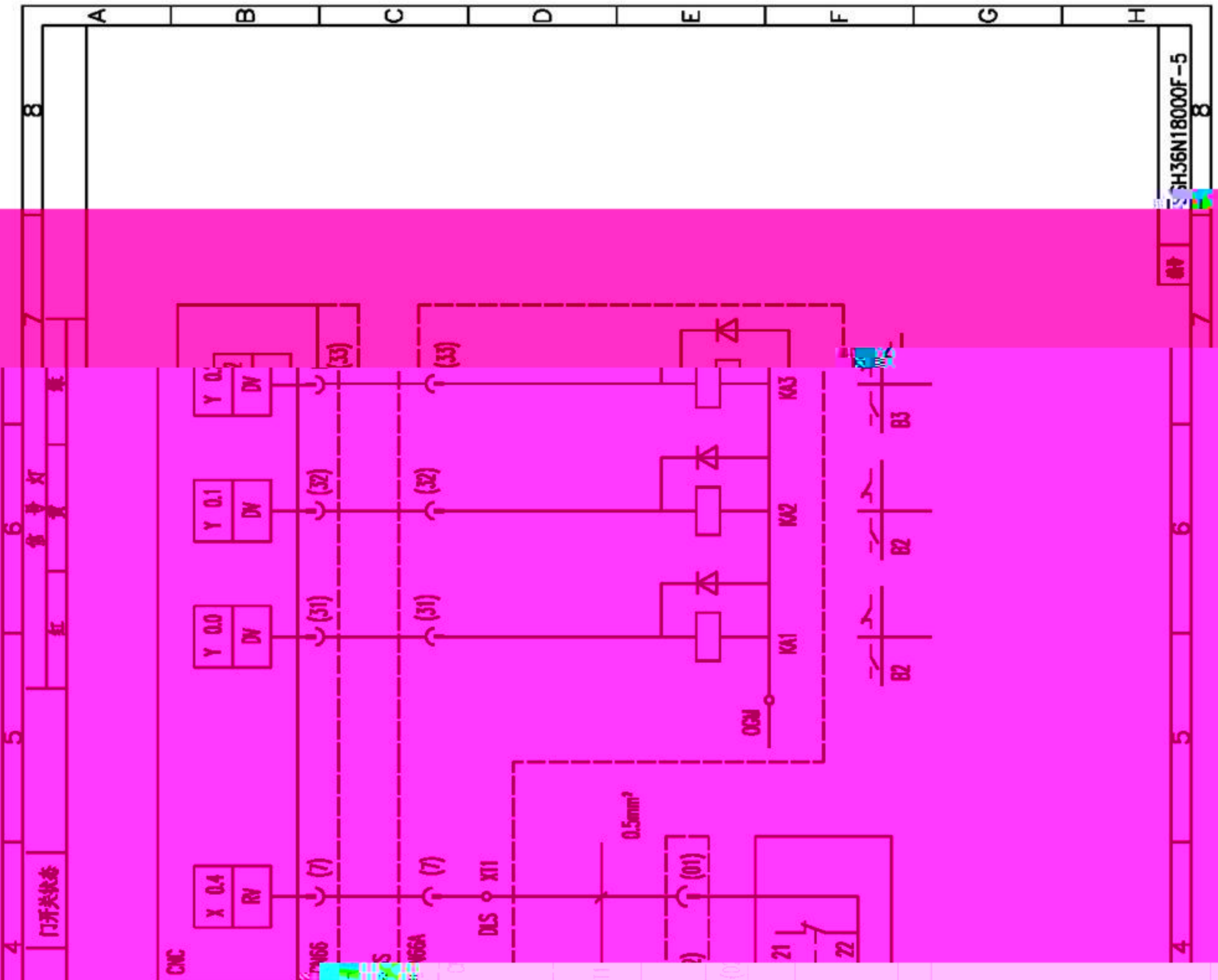

2 CNC 电路

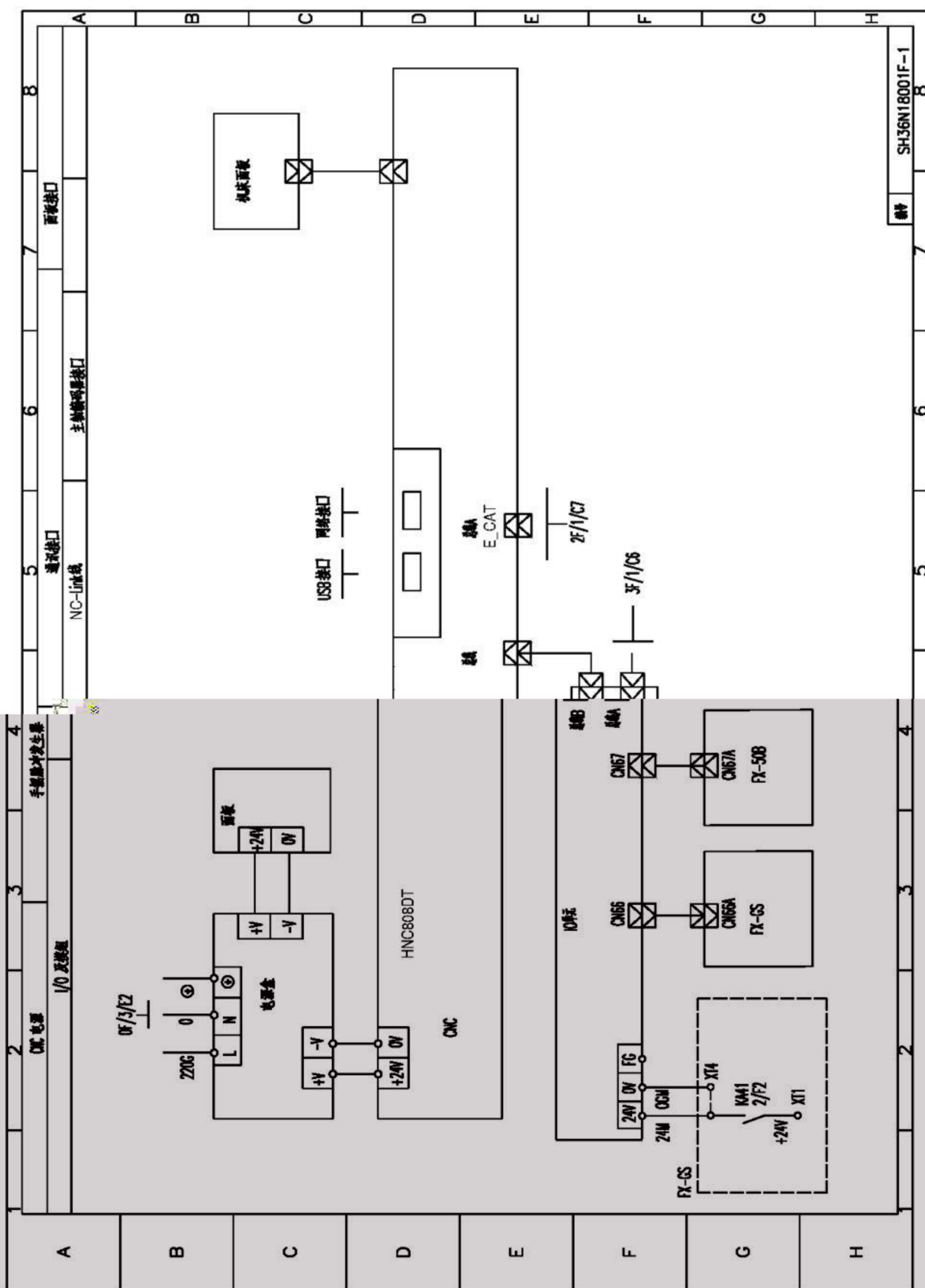

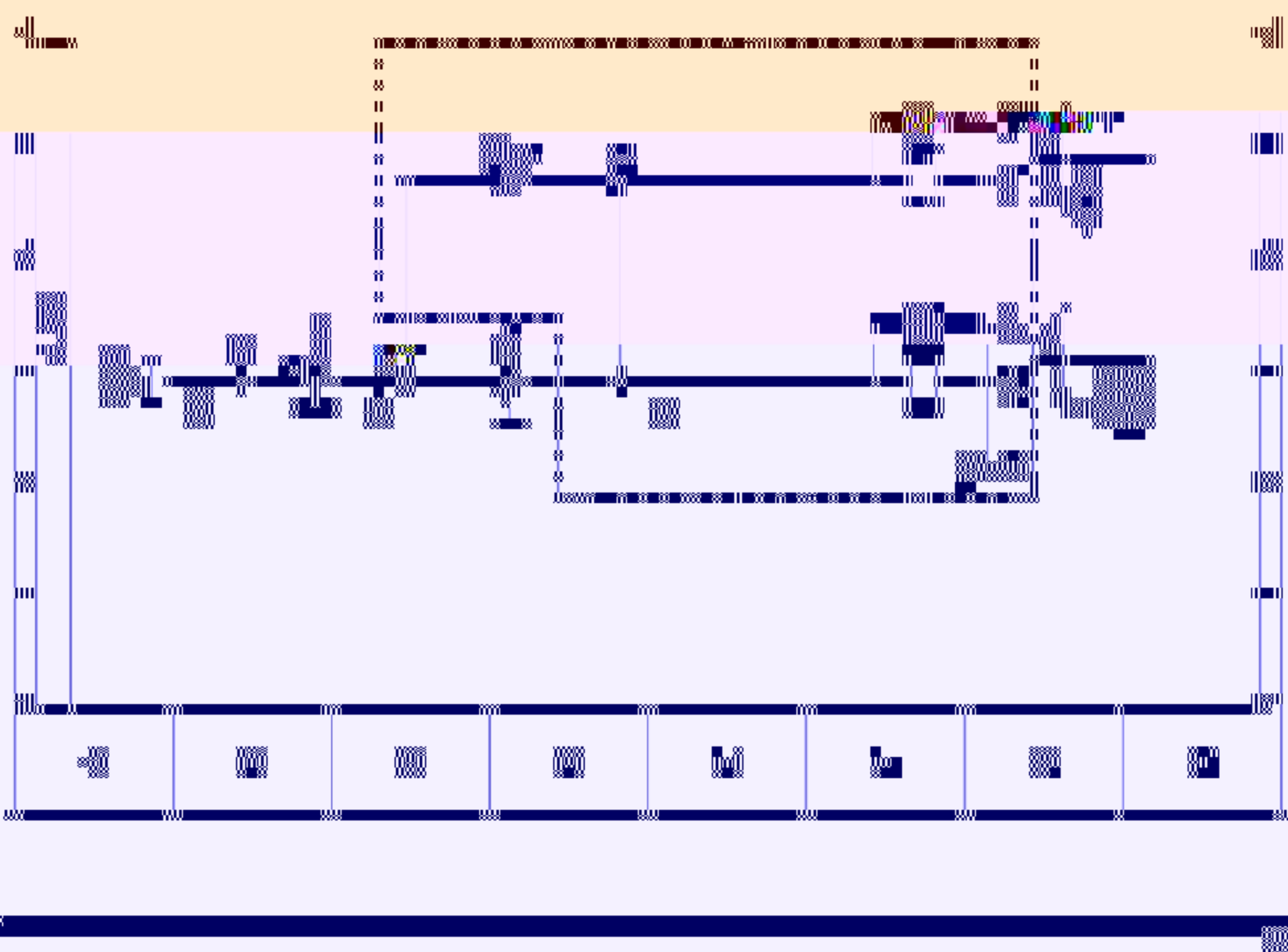
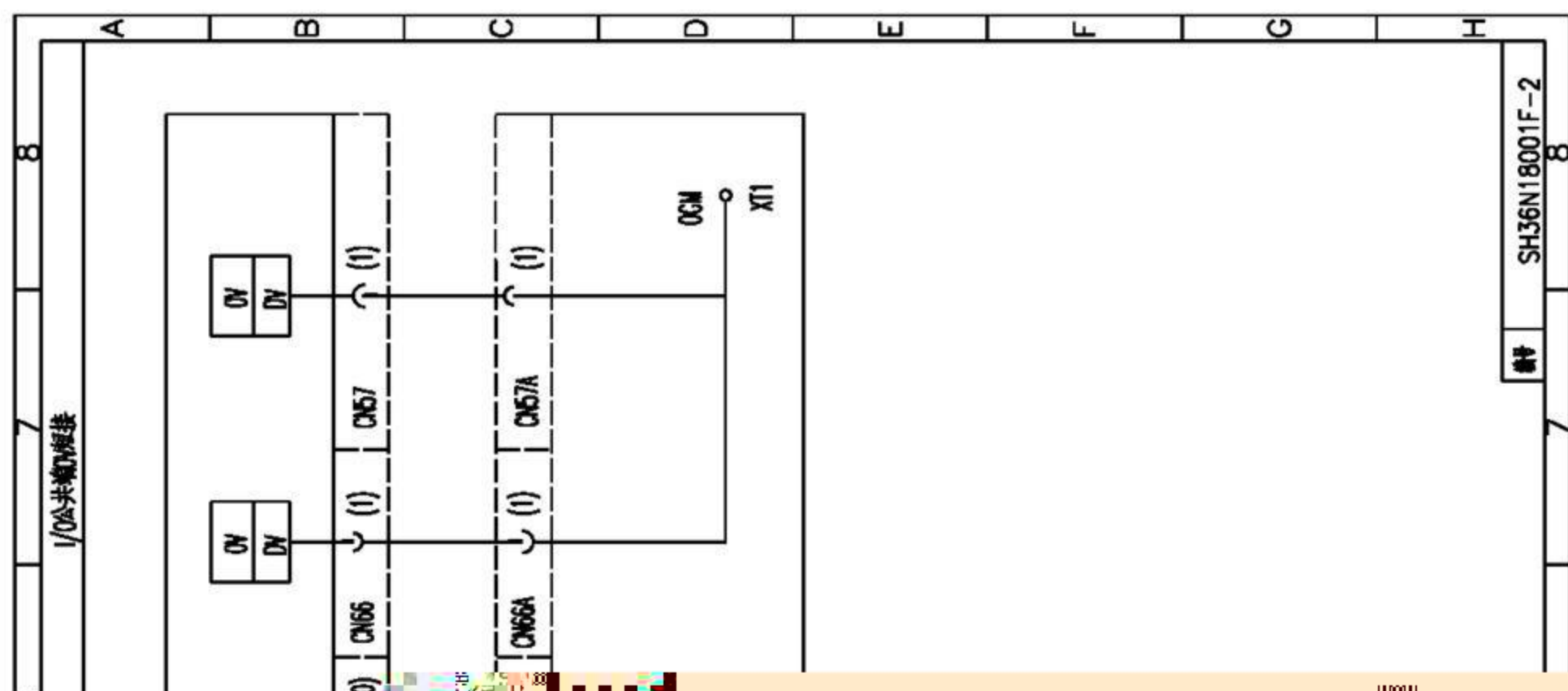

3 主轴电路

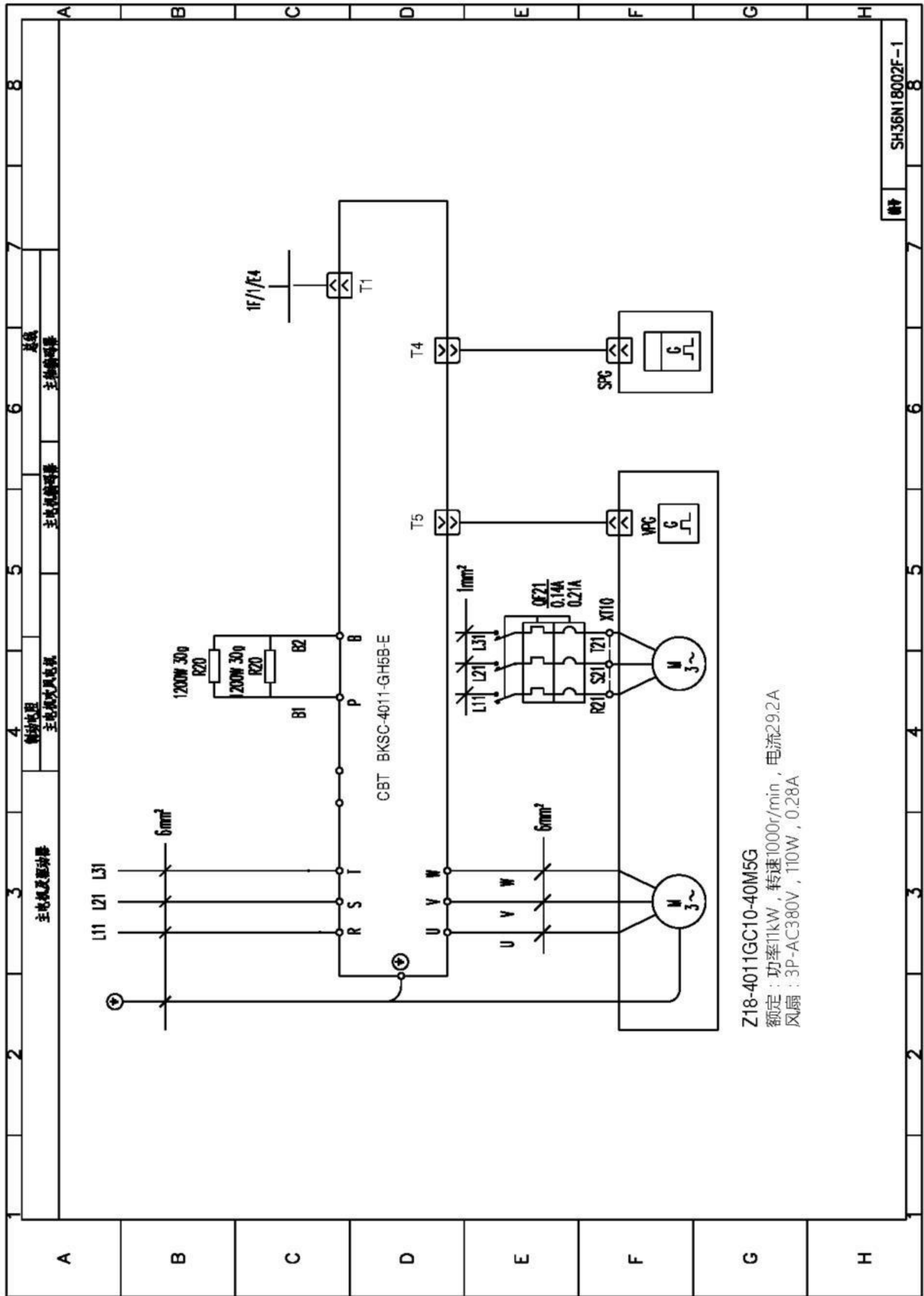

4 伺服轴电路

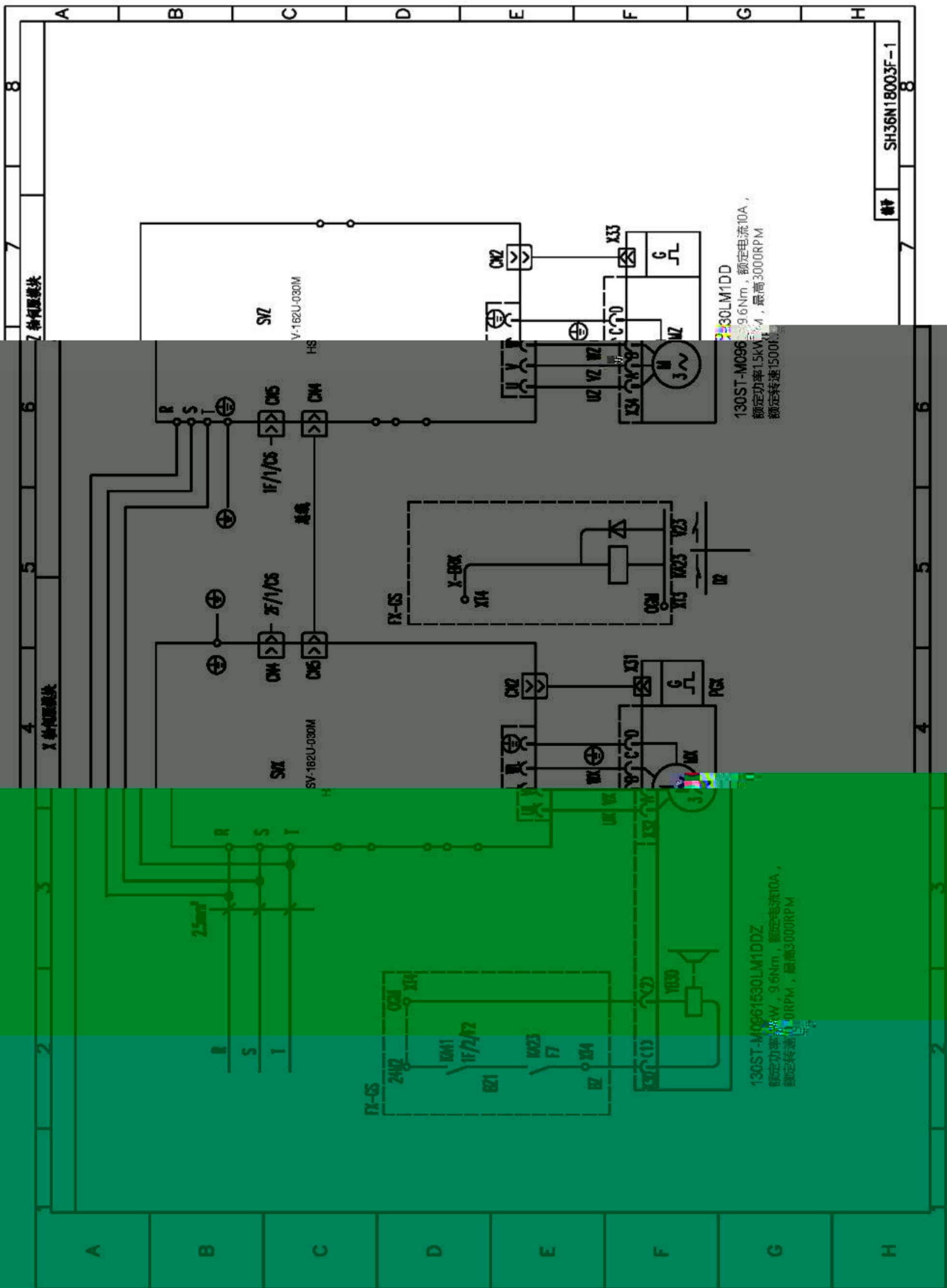

5 刀架电路

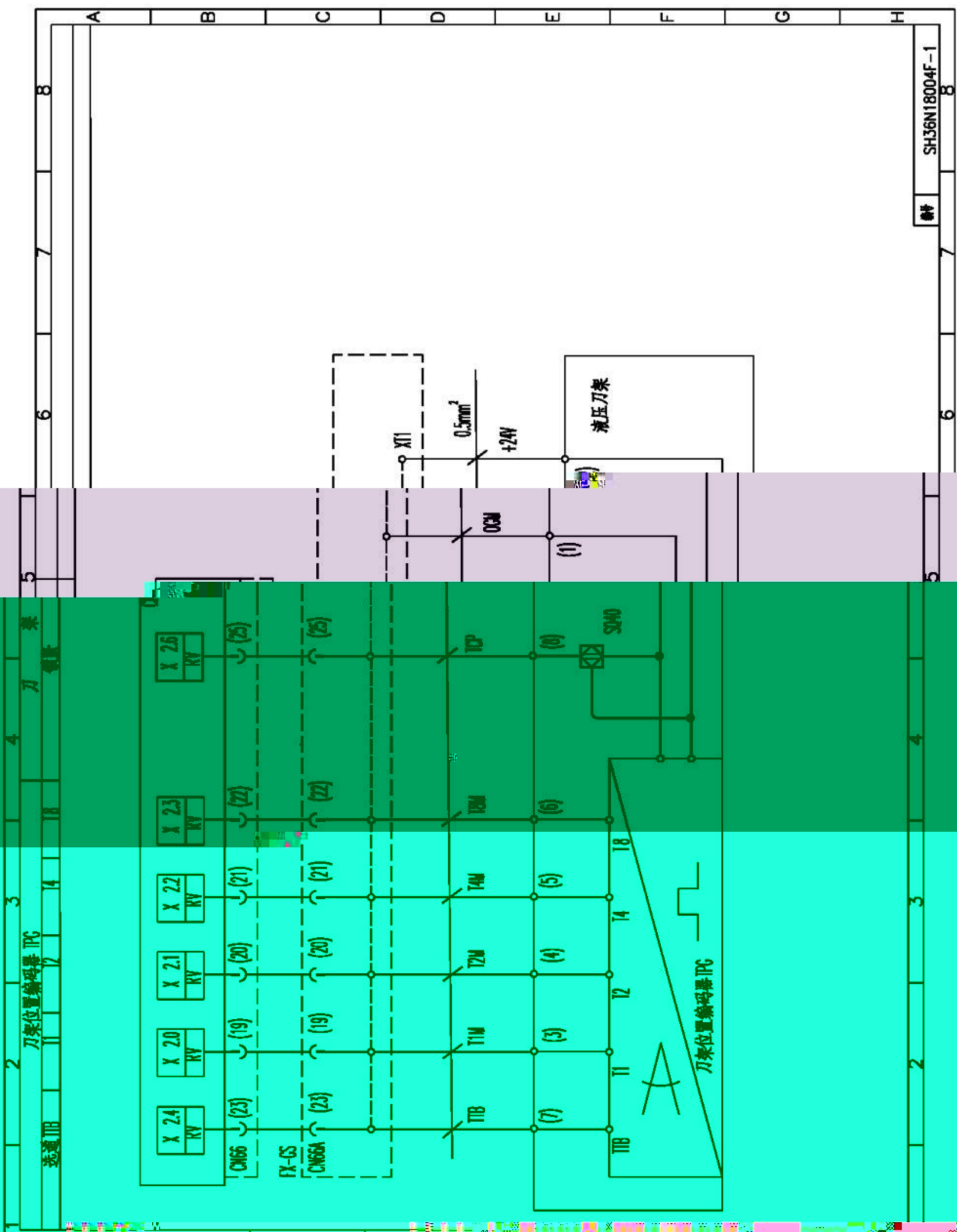

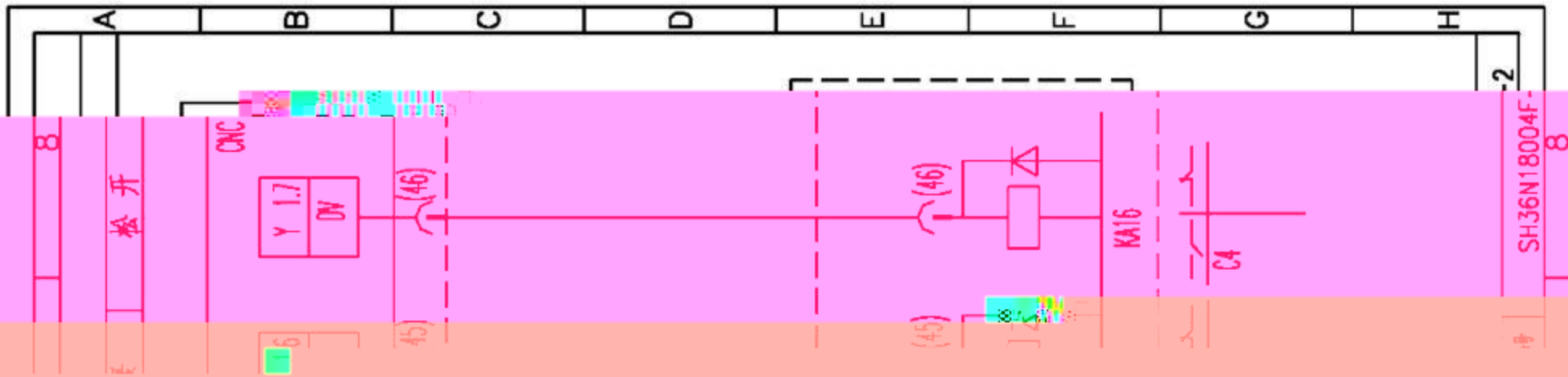

6 卡盘电路

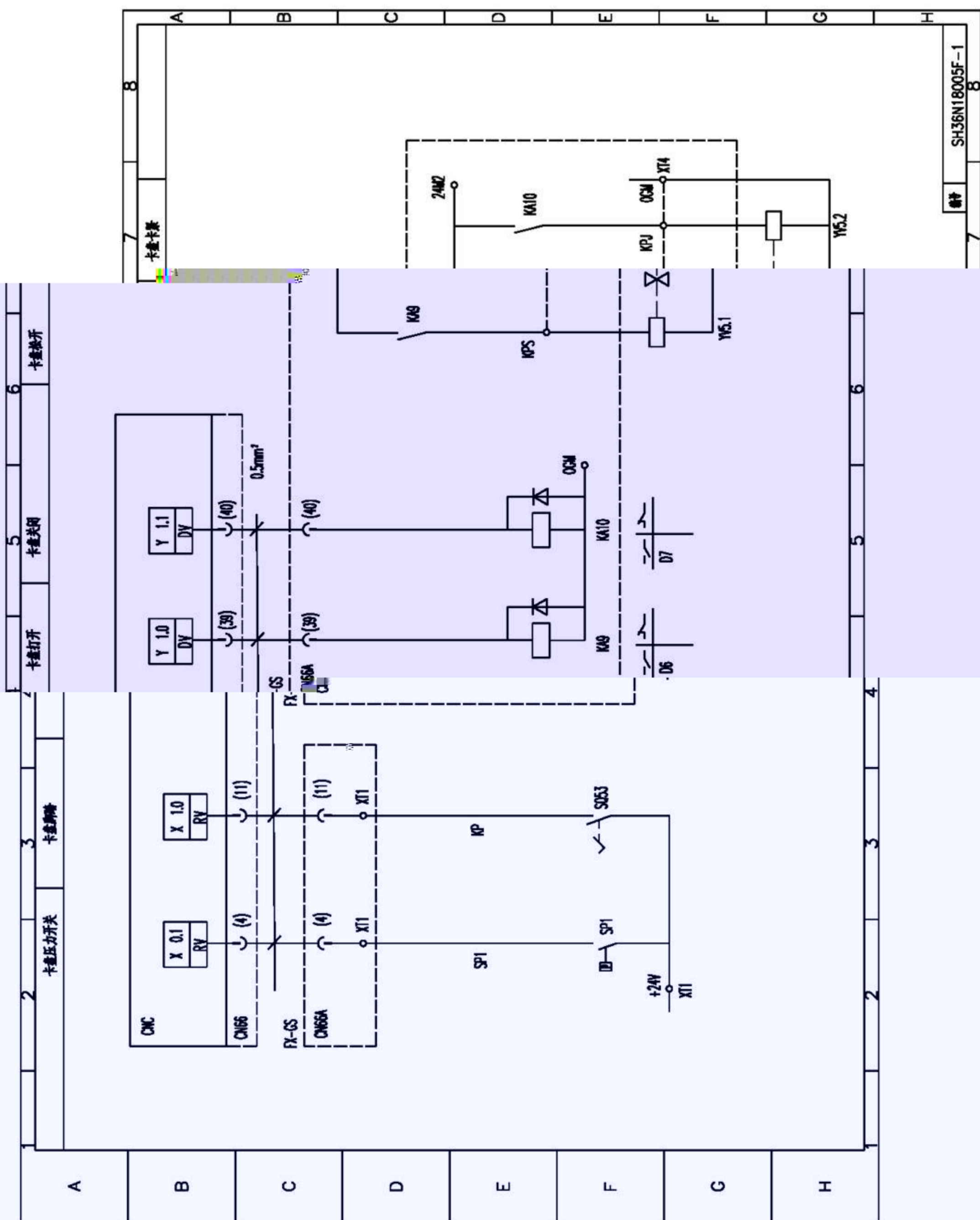

7 台尾电路

7.1 台尾套管

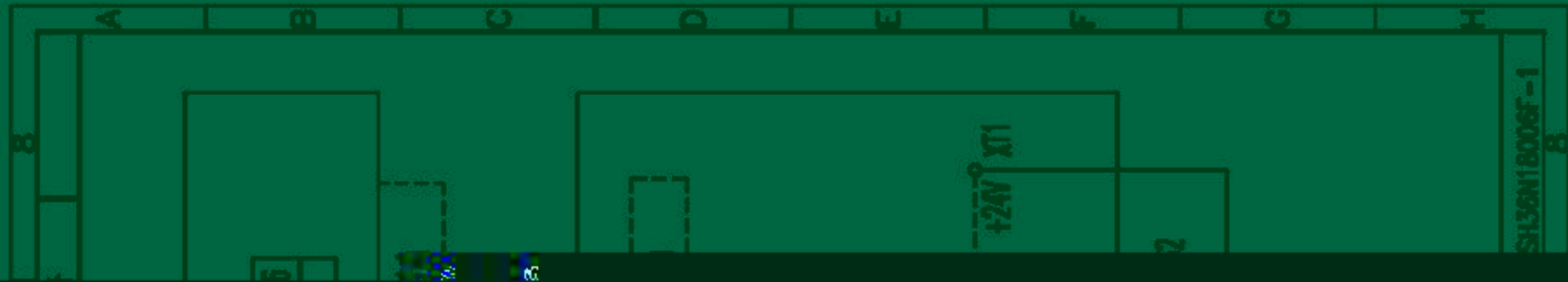

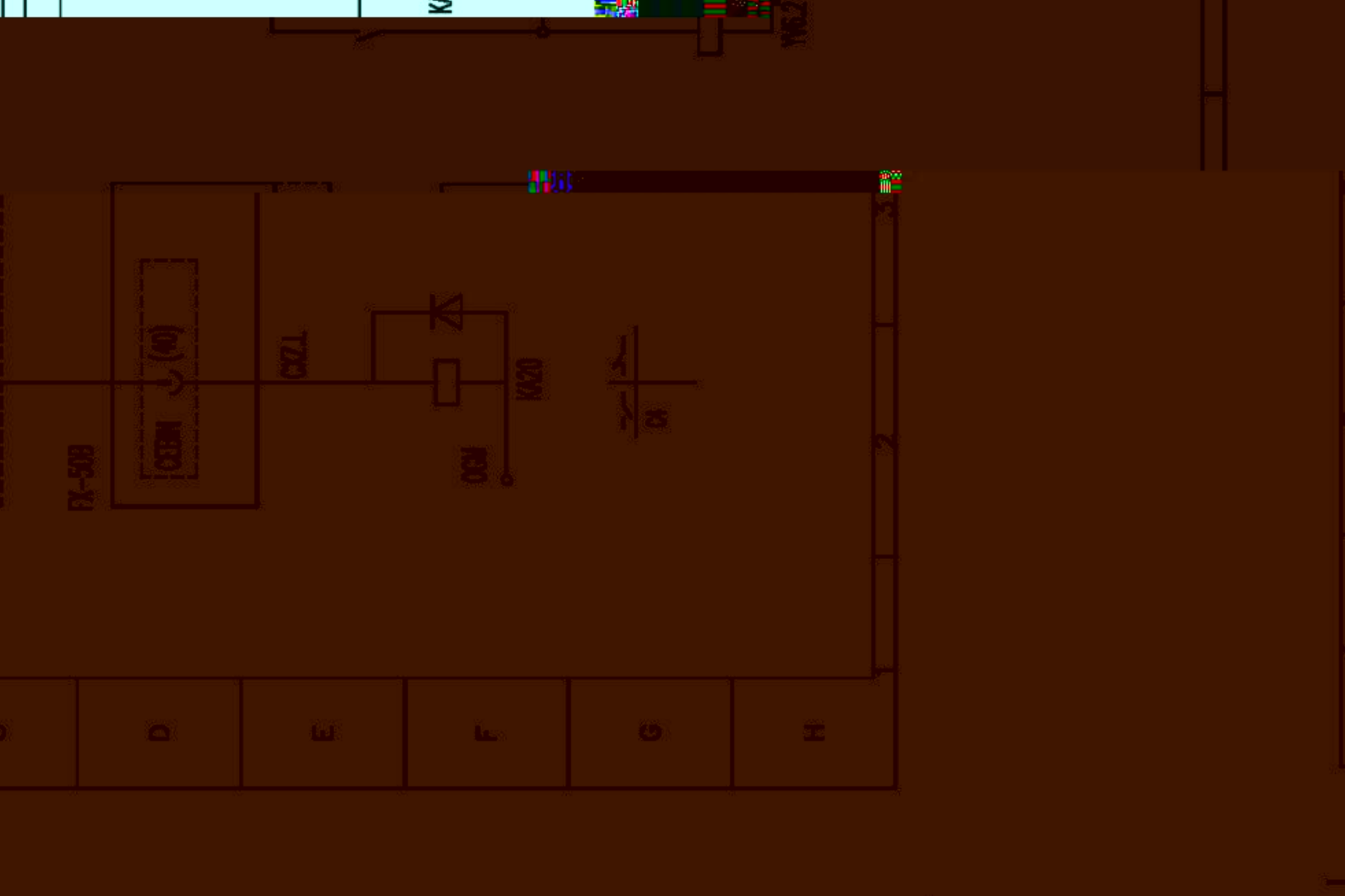
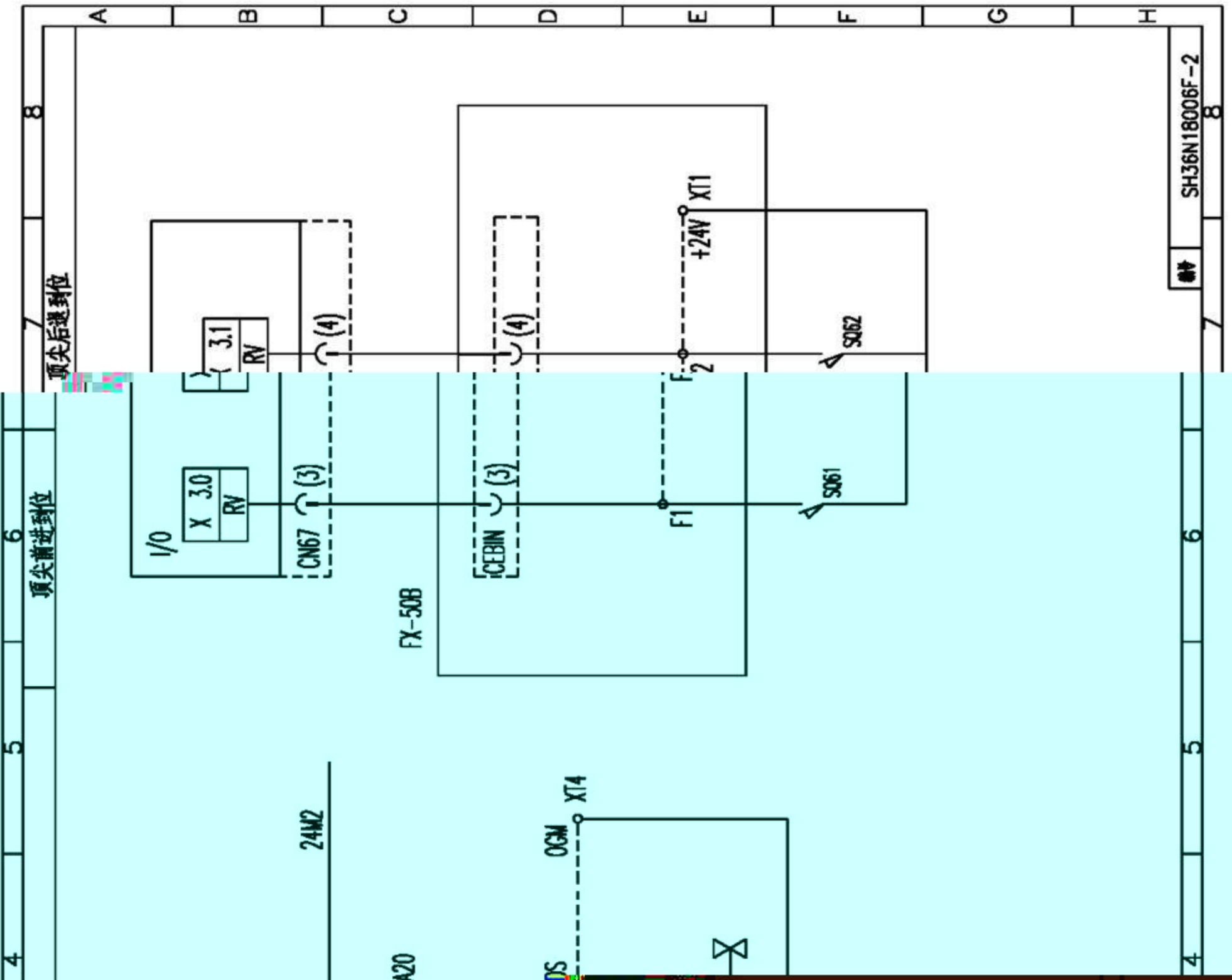

7.2 台尾体(选配)

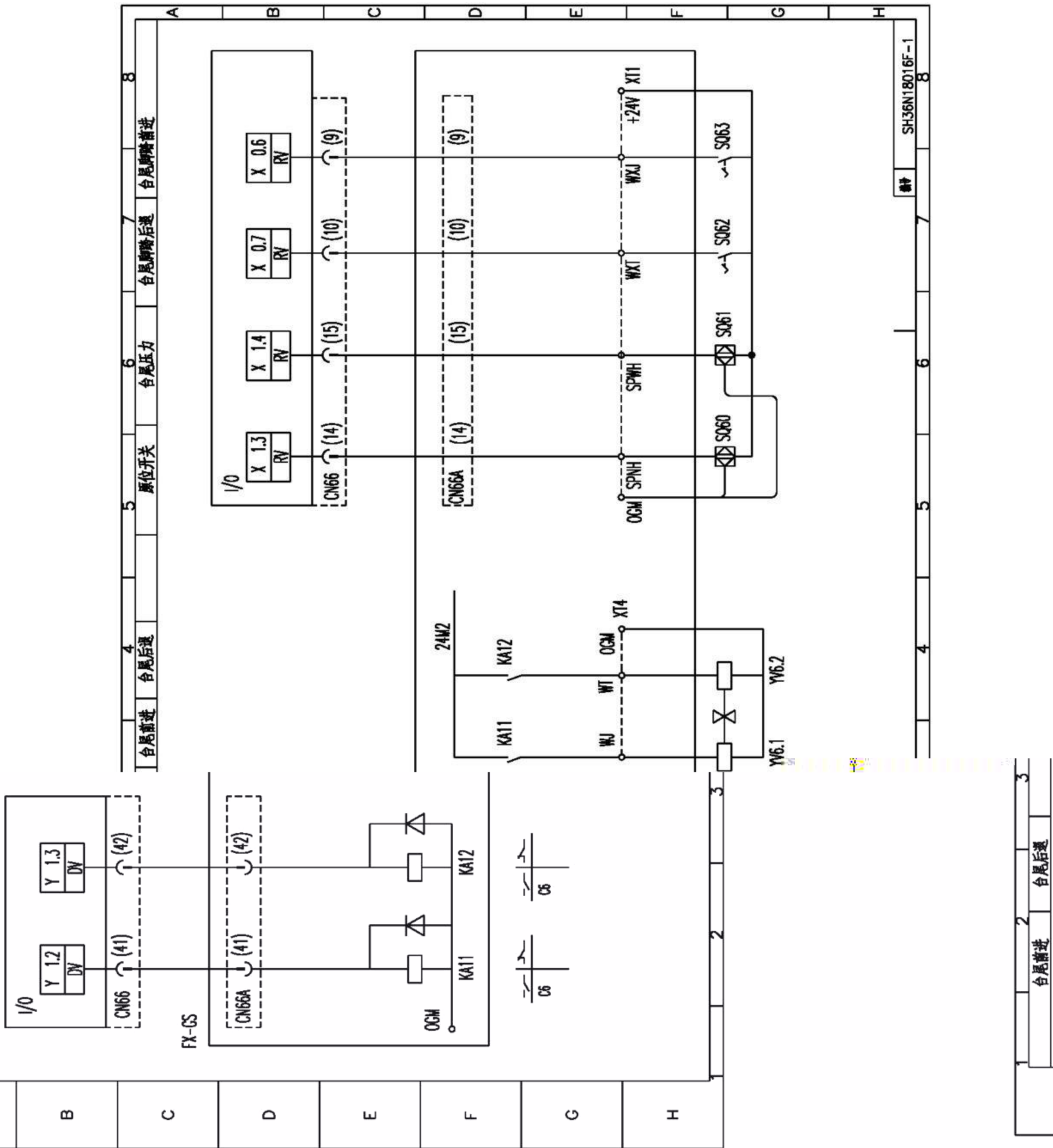

8 自动门电路(选配)

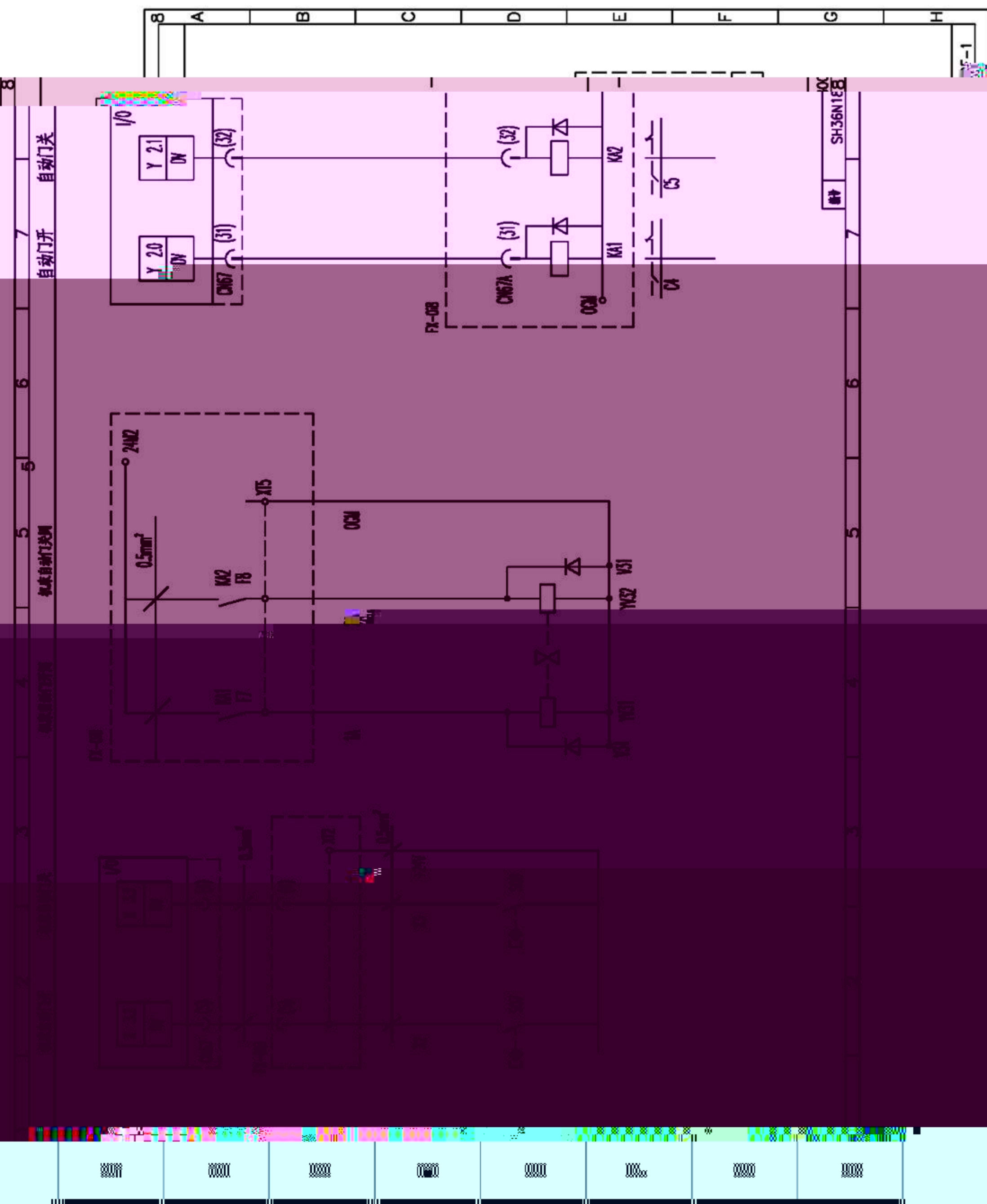

备注